

# MotorDrive Lock

## EM30-60 Digital Instructions

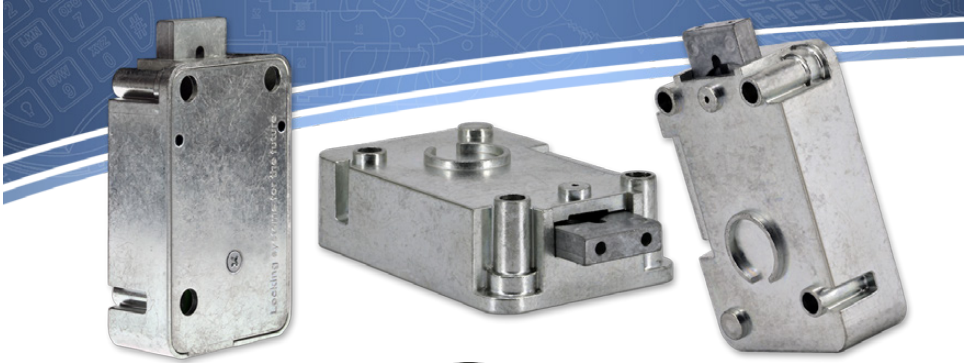

**Works With:**



DigiPro  
TE20-xx

### MotorDrive Lock Dimensions (Imperial)

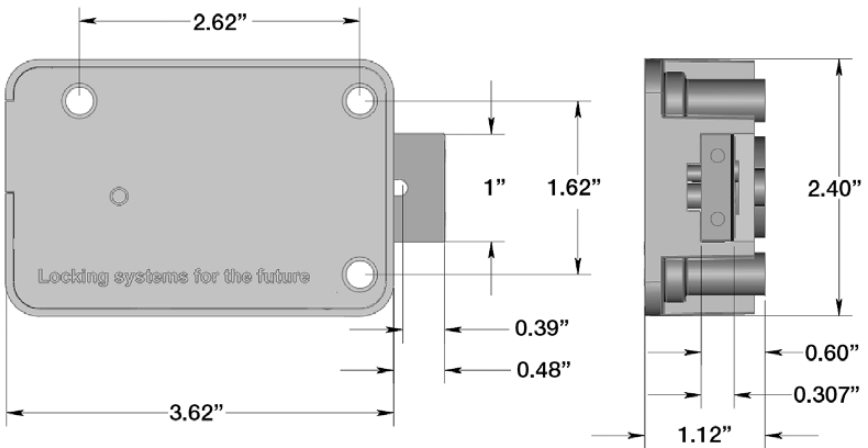

# MotorDrive Lock

## EM30-60 Digital Instructions



### GENERAL

A double beep follows entry of a valid code, as well as bolt retraction and extension.  
A long beep follows entry of an invalid code. If 10 seconds elapse without a key press, the code entry will be cancelled. Entering a valid code (double beep) activates the motor and the bolt retracts (double beep). The safe boltwork can then be moved into the OPEN position. After approximately 5 seconds (automatic closing mode) or when any key is pressed (manual closing mode), the motor will be heard releasing the lock bolt against the boltwork. After restoring the safe boltwork to the fully LOCKED position, the EM30-60 bolt fully extends and automatically secures (double beep).

### MOUNTING INSTRUCTIONS

The EM30-60 may be mounted in any of four mounting directions (LH, RH, VU or VD). Mounting dimensions are industry standard. Insert the connector from the keypad into the inner lock housing receiver (see figure 1). Ensure that the connector is fully seated. To remove the connector, carefully lift and pull away from the lock body.

Use only the supplied 1/4-20 (or M6) screws to mount the lock. Tighten the screws securely so the lock body is firmly attached to the flat mounting surface. Use of screw locking glue (i.e. Loctite) is recommended. Secure cables away from moving parts.

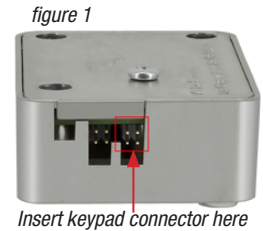

### ELECTRONICS TEST

Like all of our locks, the EM30-60 Digital includes Function 5 - a unique feature to test for proper functioning of the electronics:

- Press and hold [5] until double beep and the LED stays on
- Enter all keys in numerical sequence: 1-2-3-4-5-6-7-8-9-0
- A double beep at each key press indicates that the lock and keypad are communicating and performing properly
- A long signal indicates a fault that can likely be corrected by replacing the keypad

### BOLTWORK REQUIREMENTS

In the LOCKED position, the required distance between the lock bolt and the cavity in the movable boltwork must be a minimum of 1/16"

In the UNLOCKED position, the clearance between the lock bolt and the blocking bar must not exceed 13/64" (5mm)

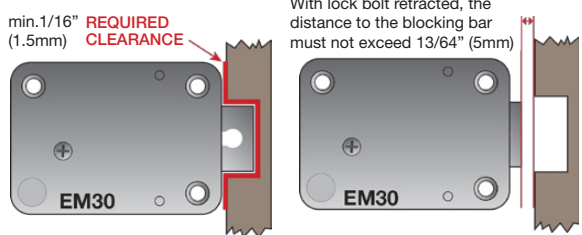

# Premier Vision TE20-Nx (30x) Installation

## FEATURES

Battery: Accessible via a sliding door at the keypad base  
Finishes: ABS in Black or Bright Chrome, Metal in Satin Chrome  
OLED Screen: Provides enhanced user feedback

## DIMENSIONS / MOUNTING INSTRUCTIONS

Cable hole diameter: 3/8" (.953mm) minimum  
The hole must be properly deburred to avoid cable damage  
The TE20-Nx (30x) mounts on horizontal (9 & 3 o'clock) studs, optional *MA2 adapter plate* required for vertical safe door mounting holes

**The hole must be properly deburred to avoid cable damage**

Affix the two #8-32 (or M4) mounting studs to the safe door  
Open the battery door and extend the battery connector cable out through the door  
Feed the cable through the cable/spindle hole on the safe door, then slide the keypad over the #8-32 (or M4) mounting studs and push down until it snaps on with a distinct "click"

Insert battery into keypad and slide the door closed  
Use ONLY Energizer or Duracell ALKALINE or LITHIUM batteries

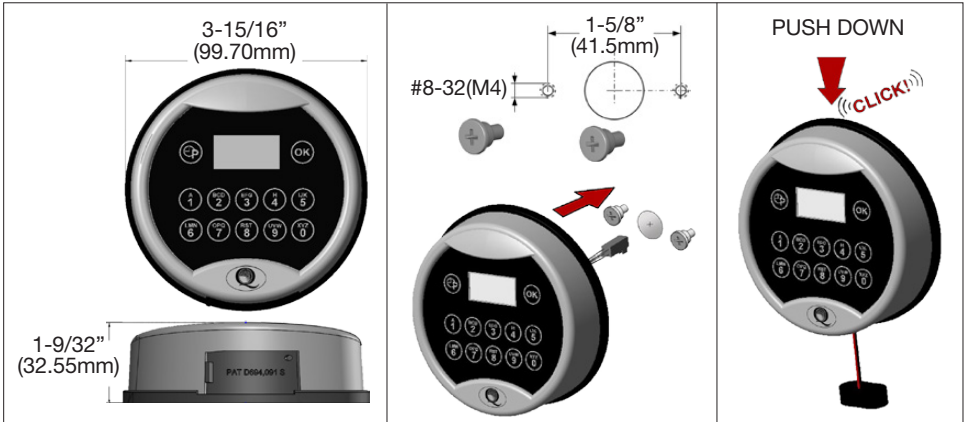
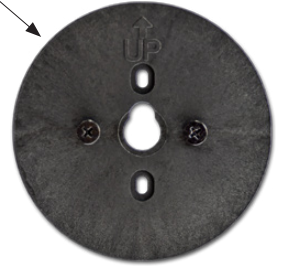

## TE20-Nx-60

**Works With:**

EM30-60  
MotorDrive  
Lock



**For Complete Programming Instructions,  
please refer to the Digi, DigiPro or LockPlus  
Technical Reference Manuals**

available at:

[QSecurityProducts.com/Resources](http://QSecurityProducts.com/Resources)

For updates and  
additional information



## WHO is QSecurity?

QSecurity is owned by Clay Miller and April Truitt. Staff includes industry veterans Deanna DeBorde, Steve Robinson, Ellis Gibbs, Ryan Griffeth, Lisa Young & others and is ever expanding. QSecurity Products, QSecurity Education and QTactical are all divisions of QSecurity Industries, the parent company.

## WHAT is QSecurity?

QSecurity is the new name for a decades-old security technologies and education company headquartered in Nicholasville, Kentucky. QSecurity began as Lockmasters, Inc.®, the locksmith education company founded by Harry C. Miller, Jim Taylor and Leonard Singer in 1955. Clay Miller and his team took over operations from Harry Miller in 1981, expanding into tool and equipment sales to the trade in 1982. The following decade saw the birth of LockNet, SAVTA and the X0-7. In 2005, Mark Miller took over the tool & equipment division, moving it into a purpose-built location just up the road on John Watts Dr. Ever eager for expansion, Mark subsequently took over the Lockmasters Education Division in 2013. Clay Miller and his engineering team remained in the S. Main Street location, focused on R&D for the clandestine world as LTI: Lockmasters Technologies, Inc. and QTactical. Just prior to his passing in 2020, Clay Miller's son Mark Miller sold Lockmasters to the Dominus Group. As a contingency of the sale, the Miller family was compelled to relinquish their rights to the Lockmasters trademark – FOREVER. LTI was forced to rebrand, and Q Security was born.

## WHY QSecurity?

The Millers have long been loyal James Bond fans. Who doesn't remember "Q," the Quartermaster of MI6, the British Secret Service? One of the most enduring characters throughout the Bond franchise, Q headed up Q Branch, the R&D division which supplied Bond with a stunning array of offensive and defensive gadgets over the years. When a rebrand became inevitable, the incorporation of "Q" seemed a novel but logical choice.

## WHERE is QSecurity?



Over the years, Lockmasters, LSI and LTI have all called Nicholasville, Kentucky home. Naturally, Nicholasville is also now the headquarters for all QSecurity Industries divisions.

Conveniently located in the heart of the Bluegrass region, QSecurity is proud to have LockNet, Sargent & Greenleaf, Lockmasters and MBAUSA as local neighbors.

## NL Lock - What's the connection?

Legendary inventors Nick Gartner and Clay Miller have worked both together and separately in the high-security safe lock industry since the late 1960s when Harry C. Miller hired Nick at Sargent & Greenleaf in Rochester, NY. Nick eventually left S&G to found LaGard, where he developed many industry firsts: the first electronic safe lock, the HPC 1200 key machine, the 2200 key lock for safes, the SmartGard, and many others.

With Nick's health declining, in early 2023 he and Clay Miller entered discussions regarding the future of NL Lock. In late August, they inked a deal to transfer the company assets to QSecurityIndustries, and on September 5, 2023, Nick passed away, knowing his brainchild had a secure future with an industry veteran and friend who would take his innovations forward.

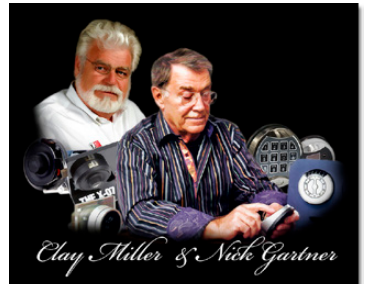

QSecurityProducts.com

Nicholasville, Kentucky, USA 40356 • 859.241.2063