

Straight Bolt

EM35-20 Instructions - Basic Board



Works With:



Premier
PI20-Rx



THinPut
TH20-D6



EasyTouch
ET20-Rx

Straight Bolt Dimensions (Imperial)

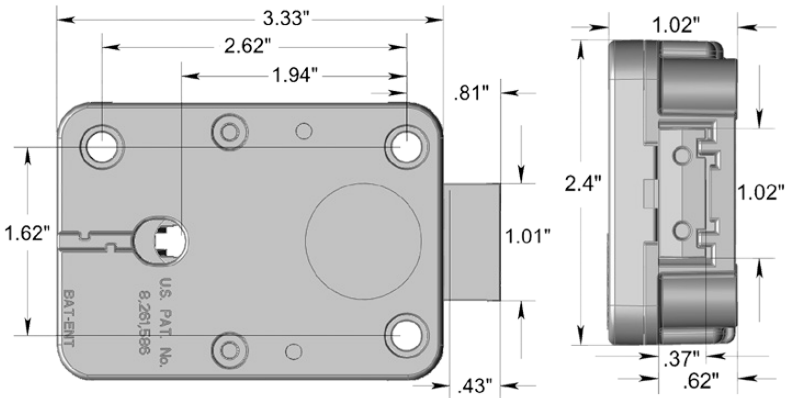

UL Type 1
VdS EN1300 Class B



Straight Bolt

EM35-20 Installation - Basic Board



FEATURES

The EM35-20 features a user-changeable 6-digit Primary code which can be used to activate or delete a Secondary user code. Entering a valid code starts a 3 second window for unlocking, allowing the lock bolt to be retracted by turning either a rotating keypad or a knob, as on the EasyTouch ET20-xx. The safe boltwork can then be moved into the OPEN position. After restoring the safe boltwork to the fully LOCKED position and extending the lock bolt by rotating the keypad or knob CCW, the EM35-20 automatically secures.

MOUNTING INSTRUCTIONS

The EM35-20 may be mounted in any of the four mounting directions (LH, RH, VU or VD). Mounting dimensions are industry standard.

Temporarily secure the lock body to the mounting surface with supplied mounting screws. Insert the grooved spindle shaft through from the face of the door until it bottoms out in the lock body. Ensuring that any adapter or trim plates are in place, use the included measuring device to mark the spindle for cutting. The spindle must extend .24" from the mounting surface of the keypad after cutting to properly engage with the chosen keypad. Deburr/Square the cut end of the spindle. Unmount the lock body. Insert the spindle into the chosen keypad and press the wire into the groove in the spindle. Feed the cable through the hole in the door, then follow separate instructions for keypad mounting.

With the lock body in hand, feed the keypad cable connector through the square opening on the underside of the lock case. Holding the cable straight, place the lock body over the grooved spindle and screw it securely to the mounting surface. Use only the supplied 1/4-20 (or M6) screws to mount the lock. Tighten the screws securely so the lock body is firmly attached to the flat mounting surface. Use of screw locking glue (i.e. Loctite) is recommended). Insert the connector from the keypad into the outer lock housing receiver labeled ENT. Ensure that the connector is fully seated. To remove the connector, carefully lift and pull away from the lock body. To secure the cable, push it into the square groove on the lock cover. Secure any excess away from moving parts.

ELECTRONICS TEST

Like all of our Locks, the Straight Bolt includes Function 5 - a unique feature to test for proper functioning of the electronics:

- Press and hold [5] until double beep and the LED stays on
- Enter all keys in numerical sequence: 1-2-3-4-5-6-7-8-9-0
- A double beep at each key press indicates that the lock and keypad are communicating and performing properly
- A long signal indicates a fault that can likely be corrected by replacing the keypad

FUNCTIONAL TEST (With door OPEN)

Enter valid code or factory code (1-2-3-4-5-6), double beep = valid entry

- Rotate keypad or knob CW to retract lock bolt
- The bolt must move freely
- Turn boltwork handle to OPEN position
- Turn boltwork handle to the LOCKED position
- Rotate keypad or knob CCW to extend lock bolt
- The bolt must fully extend and secure
- Ensure that there is at least 1/16" clearance on ALL sides of the lock bolt when the safe boltwork is in the fully LOCKED position

IMPORTANT: Repeat the functional test several times before locking the safe door!

BOLTWORK REQUIREMENTS

In the LOCKED position, the required distance between the lock bolt and the cavity in the movable boltwork must be a minimum of 1/16"

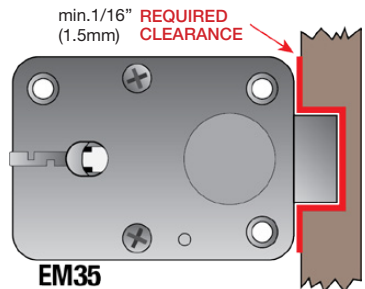

Straight Bolt

EM35-20 Operation - Basic Board



GENERAL

The EM35-20 features a user-changeable 6-digit Primary code which can be used to activate or delete a Secondary user code. A double beep follows entry of a valid code. A long beep follows entry of an invalid code. If 10 seconds elapse without a key press, the code entry will be cancelled.

OPERATION

Enter code (factory code = 1-2-3-4-5-6), double beep = valid entry
Rotate keypad or knob CW to retract lock bolt
If not opened within 3 seconds, the lock re-secures automatically
Turn boltwork handle to OPEN position
If the first code entry fails, wait 10 seconds before re-entering

Locking / Status:

Turn boltwork handle to the LOCKED position
Rotate keypad or knob CCW to extend lock bolt
Verify locked/secure status by attempting to rotate handle

Manipulation Protection:

Upon entry of four consecutive invalid codes, the keypad is blocked and will not accept entries for 5 minutes. During this period, the LED flashes every 10 seconds and any key press causes a long beep. Upon expiration, the entry of two more invalid codes restarts the 5 minute blocking period.

Best Practices

Change the factory code before you begin using the safe! Securely store all codes.
Do not use personal data (i.e. birthdays, telephone numbers, etc.) as a code.

CHANGE CODE (With Safe Door OPEN)

Press and Hold [0] (double beep), then release
The LED remains on during the following actions:

- Enter old code (double beep)
- Enter new code (double beep) and repeat new code (double beep)
- Try new code
- In case of entry errors (long beep), the old code remains valid

ACTIVATE SECOND USER CODE

Press and hold [0]

- Enter existing 6-digit Primary code (double beep)
- Enter new Secondary code (do NOT enter 1-2-3-4-5-6 as Secondary code)
- Confirm the Secondary code (double beep) LED goes out
- The 6-digit Secondary code is now active and can open the lock

NOTE: The Change Code method above is used to change either the Primary or the Secondary code. The Primary code is required to delete the Secondary code. The Primary code can be changed, but cannot be deleted.

DELETE SECOND USER CODE

Press and hold [3] (double beep), then release
The LED remains on during the following actions:

- Enter Primary code (double beep)
- The Secondary code is deleted

LOW BATTERY INDICATION

NOTE: A series of beeps following code entry indicates a weak battery that must be replaced
Use ONLY Energizer™ or Duracell™ 9V ALKALINE or LITHIUM batteries



Straight Bolt

EM35-20 Time Delay - Basic Board



PROGRAMMING TIME DELAY • INITIAL SET-UP

Delay Range: 0-99 minutes

Open Window Range: 1-19 minutes

Press and Hold [9] (double beep), then release

The LED remains on during the following actions:

- Enter six-digit Primary code (double beep)
- Enter delay then open window times in two-digit values (double beep)

For Example: to program a 26 minute delay and 12 minute open window, enter: **[2612]**

- Re-enter new delay and open window times to confirm (double beep indicates valid operation and LED will go out) NOTE: A long beep following any entry indicates an invalid or out of range entry.

OPEN WITH TIME DELAY ACTIVATED

Enter valid six-digit code: ex. 1-2-3-4-5-6 (factory code)

Beep and LED flash at each key press

Double beep at last digit = valid code

Time delay counting starts, LED flashes every 2 seconds

When delay period elapses, open window period begins, indicated by an alternating LED flashes and beep sounds every 1 second

- Re-enter valid six-digit code
- Double beep at last digit = valid code
- Within 3 seconds, turn keypad or knob to the OPEN position

CHANGING TIME DELAY VALUES

Begin time delay by entering a valid code

Once the delay period has elapsed and during the open window, press and hold [9] until the LED remains ON, then release

- Enter the six-digit Primary code (double beep), LED will remain ON
- Enter new delay and open window times in two-digit values (double beep)
- Re-enter new delay and open window times to confirm
- Double beep = valid operation and LED will go out)

NOTE: To cancel/remove time delay, enter [0001] during the open window

Decreasing the time delay period may be done only during the open window period



To view our full line,
product updates,
instruction manuals
and warranty

